

MEDULUM



PARVATI

NANDA



IT

Viaggio in India. Sulle tracce di Parvati, sposa di Shiva e dea del matrimonio, figura benevola venerata dalle donne indiane che le rendono omaggio indossando preziosi anelli al naso.

La collezione - declinata in tre varianti differenti: Nanda, nella versione cabinet e cassettera, e la madia Uma - emerge per l'utilizzo di legni dalle nuances decise e vivaci, da cui emergono evidenti le venature della materia, e per la presenza di texture vibranti e multicolor che rimandano alla cultura psichedelica degli anni '60: nel corso di quel periodo, numerosi artisti viaggiarono attraverso le regioni indiane e si immersero in questa cultura sfaccettata e multiforme, mixandola poi con quella occidentale per dare vita a capolavori della musica e dell'arte.

La natura composita di Parvati identifica inoltre la dea quale consorte di Shiva e simbolo di devozione coniugale: ancora oggi, le donne indiane le rendono omaggio indossando al naso preziosi anelli d'oro, monili dal forte valore simbolico. Traendo ispirazione proprio da questo aspetto, la collezione proposta dal brand rivela quindi un ulteriore tratto comune, la presenza di una maniglia gioiello in ottone: un cameo di raffinata particolarità per una serie di arredi dal carattere unico e inconfondibile.

DESIGNER

Serena Confalonieri

ANNO DI PRODUZIONE

2022

EN

Journey to India. On the path of Parvati, Shiva's bride and goddess of matrimony, a benevolent figure venerated by Indian women who pay homage to her by wearing precious nose rings.

The collection - available in three different variants: Nanda, in the cabinet and chest of drawers version, the Uma sideboard - stands out for its use of woods with decisive and vivacious nuances. The woodgrain catches the eye in addition to the presence of vibrant, multi-coloured textures which hark back to the psychedelic culture of the 1960s: during that period, numerous artists journeyed around India and immersed themselves in this multi-faceted and multifarious culture, mixing it back into the Western one to create musical and artistic masterpieces. The compositional nature of Parvati also identifies the goddess as consort of Shiva and symbol of marital devotion: still today, Indian women pay homage to her by wearing precious gold rings on their noses, jewellery with a strong symbolic value. Drawing inspiration precisely from this aspect, the collection proposed by the brand has a further common aspect, the presence of a brass feature handle: a cameo of refined distinctiveness for a collection of furnishings with a unique and unmistakable character.

DESIGNER

Serena Confalonieri

PRODUCTION YEAR

2022

NANDA



Gli accessori di Nanda, gambe di supporto, cerniere per apertura ante e maniglie, sono realizzate in metallo ottonato lucido e danno a questo cabinet l'aspetto di un prezioso gioiello.

Nanda's accessories such as the supportive legs, door hinges and doorknob, are made of polished, brass-plated metal and give this cabinet the appearance of a precious jewel.

▣ Arredi realizzati con impiallacciate applicate su scocca di multistrato curvato.

▣ Furnishing elements made with veneers applied to a curved plywood shell.



NANDA

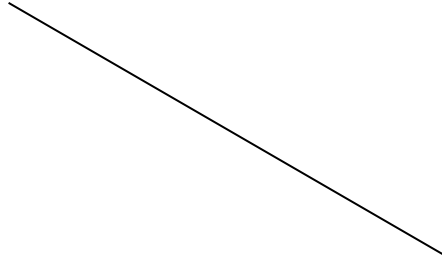

MEDULUM

NANDA

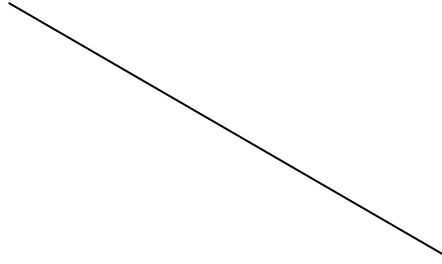

MEDULUM

UMA

Parvati, la dea benevola del pantheon induista, simbolo di amore, devozione e fertilità. È la tradizione mitologica indiana - con il suo universo affascinante di divinità creatrici e ordinatrici del cosmo - la musa ispiratrice della collezione Parvati, serie di complementi d'arredo ideata dalla designer milanese Serena Confalonieri per MEDULUM.

Parvati, the benevolent goddess of the Hindu pantheon, symbol of love, devotion and fertility. It is the Indian mythological tradition - with its fascinating universe of cosmic creator and ruler divinities - which is the inspiration behind the Parvati collection, a range of furniture created by Milanese designer Serena Confalonieri for MEDULUM.

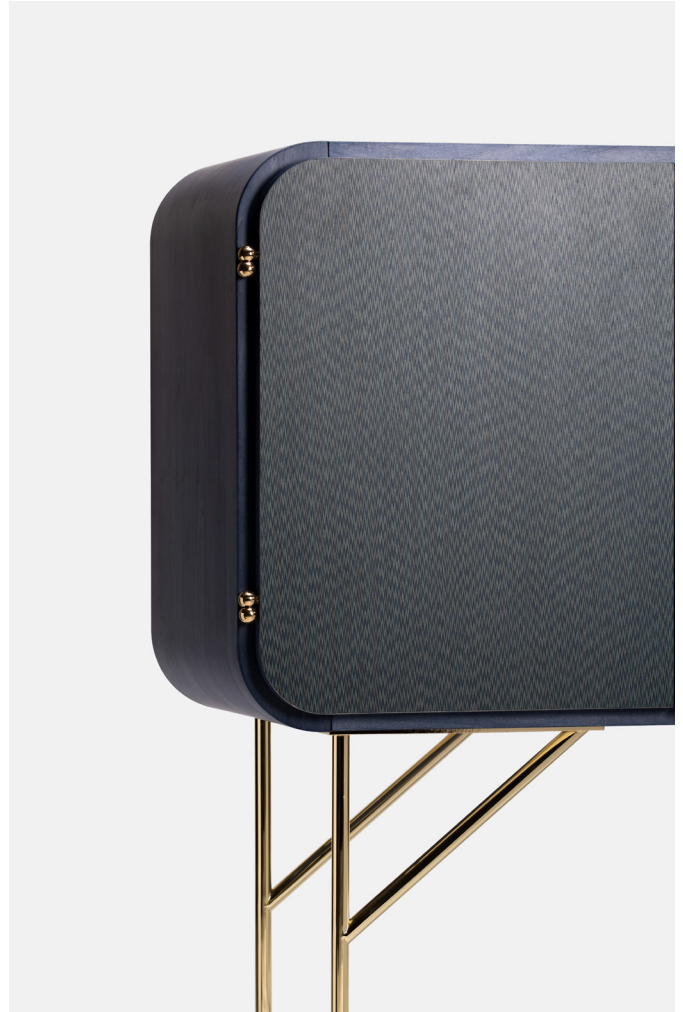

▮ Caratteristica di tutta la collezione Parvati è l'essenza effetto tessuto utilizzata per l'esterno che può essere di tonalità rossa, nera o blu.

▮ Characteristic of the Parvati collection is the fabric effect essence used for the exterior which can be red, black or blue.

UMA

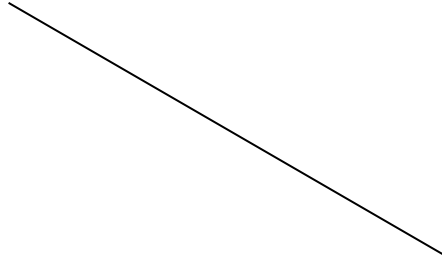

MEDULUM

TECHNICAL INFO

DIMENSIONI / DIMENSIONS

- **NAN.170** W100 x H170 x D44 cm
- 2 ante e 2 ripiani in vetro
- 2 doors and 2 shelves
- **NAN.140** W100 x H140 x D44 cm
- 5 cassettini
- 5 draws
- **UMA** W195 x H105 x D44 cm

MATERIALI / MATERIALS

Multistrato impiallacciato verniciato trasparente
 Dettagli ottonati (maniglia e parte di struttura)
 Ripiani in vetro temperato extrachiario 10mm
 Transparent varnished plywood
 Brass-plated details (handle and part of the structure)
 10mm extra-clear tempered glass shelves

FINITURE / FINISHES

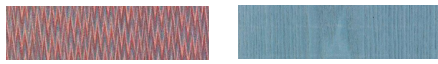

PO1
 red caleidolegno
 caleidolegno rosso

PO1.in
 ash tree blu
 frassino tinto blu



PO1.out
 red tanganyka
 tanganyka tinto rosso

PO2
 blu caleidolegno
 caleidolegno blu



PO2.in
 ash tree jellow
 frassino tinto giallo

PO2.out
 blu tanganyka
 tanganyka tinto blu



PO3
 black caleidolegno
 caleidolegno nero

PO3.in
 ash tree light purple
 frassino tinto viola



PO3.out
 black tanganyka
 tanganyka tinto nero



M3
 ottone lucido
 polished brass

M4
 acciaio ottonato lucido
 polished brass-plated steel

NAN.170

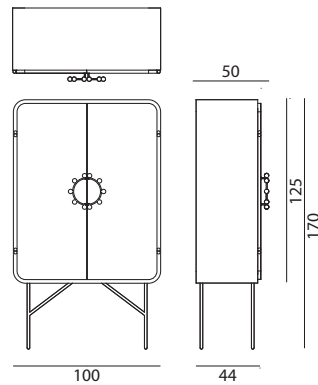

NAN.140

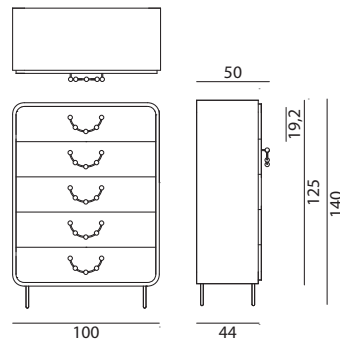

UMA

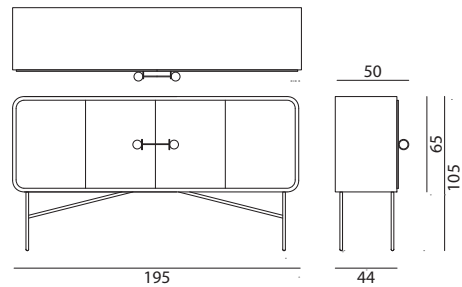

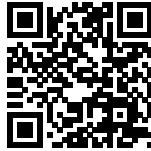

Head Office address

Via A. Toscanini 8/A - 30020 Meolo
Venice, Italy

phone number

+39 042161730

e-mail

commerciale@medulum.it

www.medulum.it

Let's keep in touch

